

POSEIDON

- your maritime training partner

Senior Salgssjef, Arne Tveit

Vi sa vi ville – og vi gjorde det!



Sikkerhetssenteret
Ytre Namdalen videregående skole
7900 Rørvik

Søknad om godkjenning som opplæringssted - hurtigbåtkurs

Vi viser til søknad datert 02.07.2004 hvor det søkes godkjenning av følgende kurs:

1. Hurtigbåtkurs. Fører og navigatør
2. Hurtigbåtoperasjon. Maskinist og øvrig besetning
3. Utvidet re-treningskurs for tidligere utsjekket fører og navigatør
4. Hurtigbåt re-treningskurs for fører og navigatør
5. Hurtigbåt re-treningskurs for maskinist og øvrig besetning

Sjøfartsdirektoratet godkjenner søknaden i henhold til §1-5 i gjeldende forskrift av 09.05.2003, nr. 687 om kvalifikasjonskrav, utstedelse av sertifikater og om sertifikatrettigheter for personell på norske skip, fiske- og fangstfartøy og flytbare innretninger; samt Rundskriv Serie I nr. 13/2002 av 12.juli 2002 "Instruks om godkjenning av maritime utdannings- og opplæringsinstitusjoner."

Godkjenningen gjelder for 5 år, men kan til enhver tid trekkes tilbake dersom Sjøfartsdirektoratet finner at institusjonen ikke tilfredsstillter kravene eller forskriftene.

Med hilsen

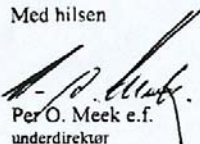

Per O. Meek e.f.
underdirektør



Helge Eik
senioringeniør

Send dokumenter elektronisk. Sjøfartsdirektoratet oppfordrer alle som har mulighet til å sende inn brev og dokumentasjon elektronisk som e-post til postmottak@sjofartsdir.no. Vedlegg i størrelse inntil A3 kan sendes på formatene til MS Office, Acrobat Reader, eller scannet som bilder i TIF-format.

Postadresse Postboks 8123 Dep 0032 Oslo Norge	Kontoradresse Stensberggt 27 0170 Oslo Norge	Telefon 22 45 45 00	Telefaks 22 45 45 01 E-post postmottak@sjofartsdir.no	Organisasjonsnummer NO 974 761 262 MVA Internett www.sjofartsdir.no
--	---	------------------------	--	--

Sikkerhetssenteret
Ytre Namdalen videregående skole
7900 Rørvik

Søknad om godkjenning som opplæringssted - hurtigbåtkurs

Vi viser til søknad datert 10.08.2004 hvor det søkes godkjenning av følgende kurs:

1. Hurtigbåttassessor kurs.

Sjøfartsdirektoratet godkjenner søknaden i henhold til §1-5 i gjeldende forskrift av 09.05.2003, nr. 687 om kvalifikasjonskrav, utstedelse av sertifikater og om sertifikatrettigheter for personell på norske skip, fiske- og fangstfartøy og flytbare innretninger; samt Rundskriv Serie I nr. 13/2002 av 12.juli 2002 "Instruks om godkjenning av maritime utdannings- og opplæringsinstitusjoner."

Godkjenningen gjelder for 5 år, men kan til enhver tid trekkes tilbake dersom Sjøfartsdirektoratet finner at institusjonen ikke tilfredsstillter kravene eller forskriftene.

Med hilsen

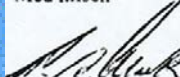

Per O. Meek e.f.
underdirektør



Helge Eik
senioringeniør

Send dokumenter elektronisk. Sjøfartsdirektoratet oppfordrer alle som har mulighet til å sende inn brev og dokumentasjon elektronisk som e-post til postmottak@sjofartsdir.no. Vedlegg i størrelse inntil A3 kan sendes på formatene til MS Office, Acrobat Reader, eller scannet som bilder i TIF-format.

Postadresse Postboks 8123 Dep	Kontoradresse Stensberggt 27	Telefon 22 45 45 00	Telefaks 22 45 46 01 E-post	Organisasjonsnummer NO 974 761 262 MVA Internett
----------------------------------	---------------------------------	------------------------	-----------------------------------	--

Fiskerisimulator

240 + 40 grader view

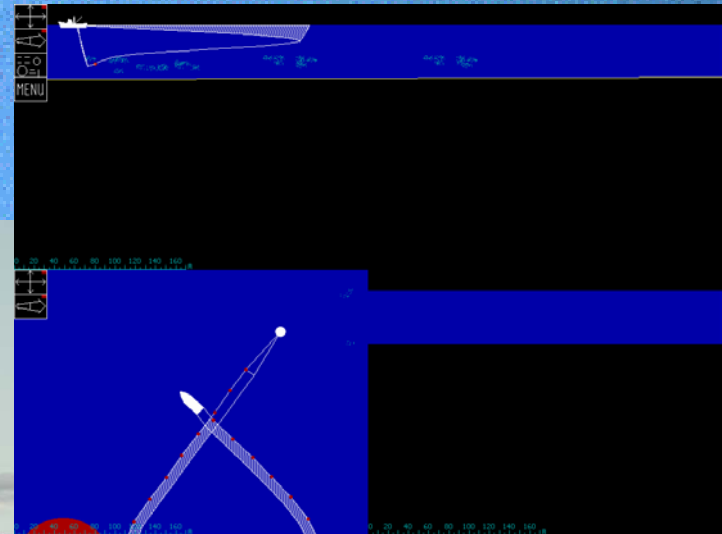

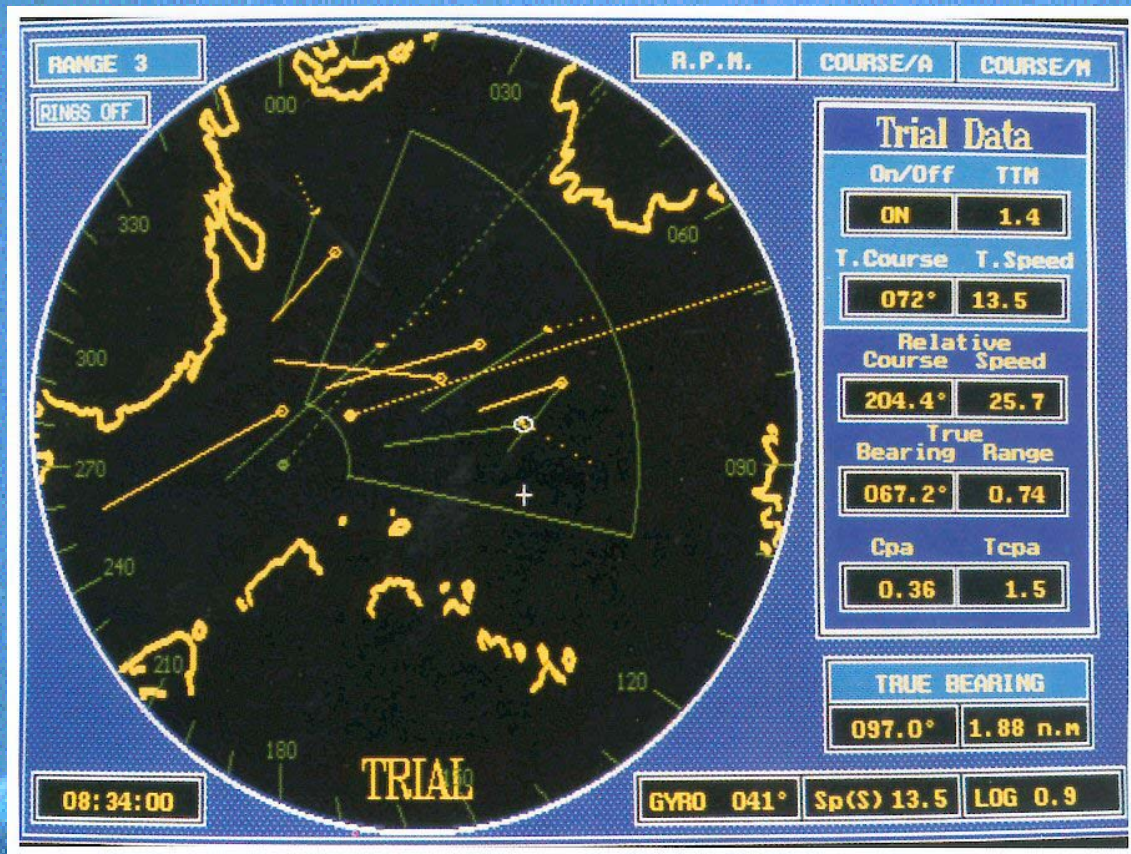

POSEIDON:
Stiftet i 1988
Leknes i Lofoten

Verdens største leverandør på GMDSS-simulatorer



POSEIDON

LATITUDE	LONGITUDE	DATE	TIME	STATION	STATUS
53°38.1' N	007°11.6' E	05 Jun 2002	14:54:46	Instructor	RUNNING

A world map with a black outline on a blue background. Numerous small, multi-colored stars (red, yellow, green, blue) are scattered across the map, primarily concentrated in North America, Europe, and East Asia, representing the locations of Poseidon simulators. The text is overlaid on the map.

**POSEIDON SIMULATORER I
BRUK OVER HELE VERDEN
(I 45 ulike land):**

**Mer enn 1600 godkjente
simulatorer installert**



GMDSS SIMULATORER



BRO- / NAVIGASJONS SIMULATORER



MASKIN-SIMULATORER

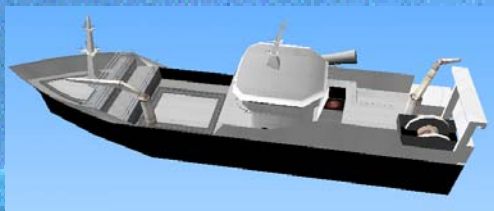

November 2004:

**Installasjon, slutt-test,
instruktørtrening:**

2 maskinromssimulatorer

2 bro/fiskerisimulatorer

1 brosimulator

2 GMDSS simulatorer

2 Radar/ARPA simulatorer

1 språksimulator





**Hardware Radar,
autopilot, GPS**

**Styring, nødstyring,
feilsituasjoner**

Brannvarsling

GMDSS kommunikasjon

Intercom

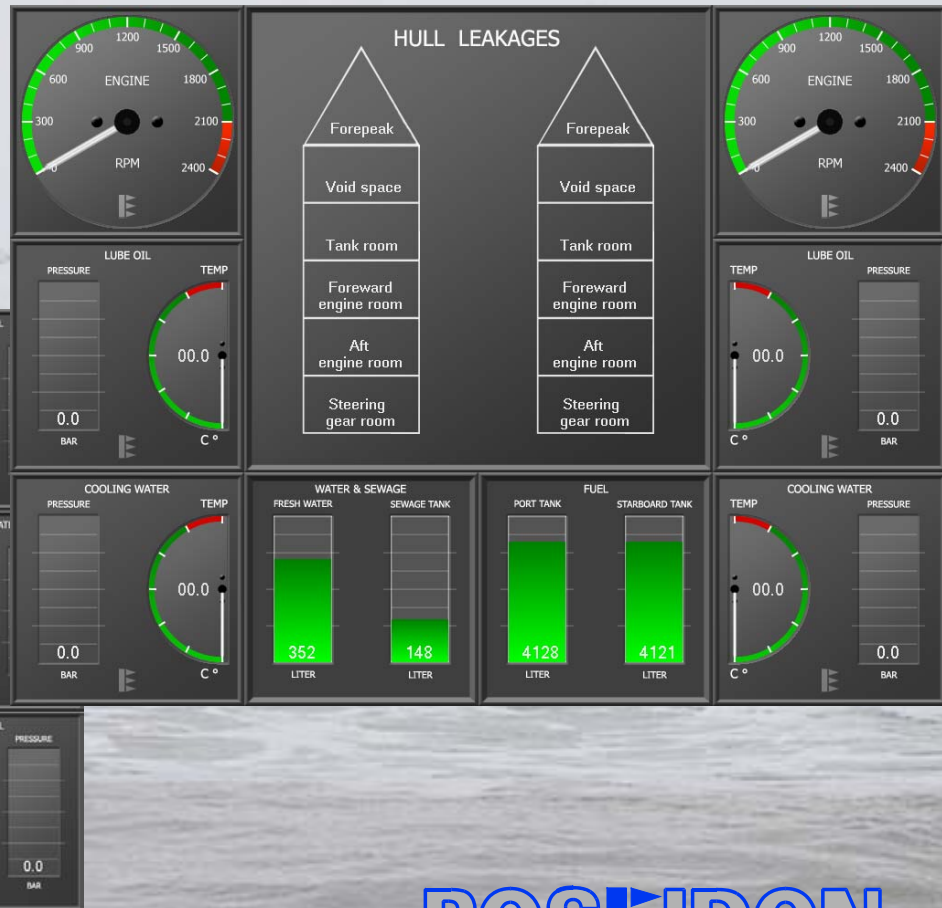



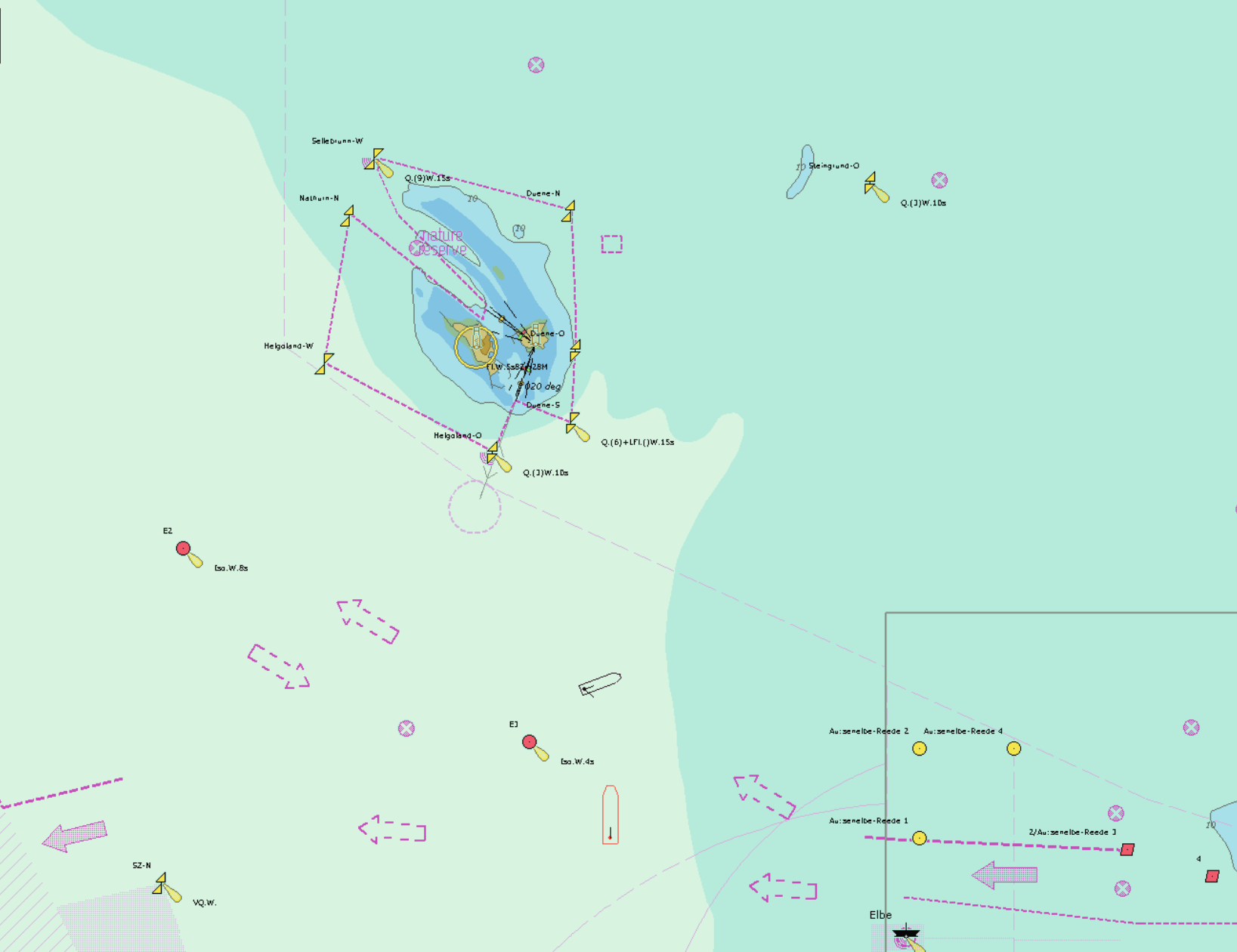

Exercise data

Area:

OS: TS:

Start Time:

Start Date:

Prec: Fog:

Wind:

Curr:

Network

No Network

Server

Status:

Clients

Target 1

P

C

NYTT MANØVER -KONSOLL

RUDDERMODE
MODE: DOUBLE SPEED

WIND
TRUE RELATIVE

DIM
+ -

LOG
RESET

VISUAL CONTROL
CENTER BINOCLARS ON/OFF

LIGHT CONTROL

POSEIDON LORAN-C
LATITUDE: N 51:10:39
LONGITUDE: E 001:28:06
COURSE: 051.0°
SPEED: 13.2 KTS

DAYSIGNALS

SOUND CONTROL
HORN HORN BELL GONG

FURUNO GPS NAVIGATOR
SIM 19 JAN 04 18:04:07
N 51:10:39
E 001:28:06
SPD: 13.2 kt CSE: 051.0°

POSEIDON RADIO DIRECTION FINDER
SEARCH FREQUENCY: 0311.0
RECEIVED RADIO SIGNAL
CALL ID: NF
BEARING: 353.7° 270 173.7°
RDF E-6

POSEIDON AUTOPILOT
MAN AUTO
AUTO 051.0°

POSEIDON ECHO SOUNDER
DEPTH: 22.0 M SPEED: 13.7 KTS

POSEIDON RATE OF TURN

POSEIDON RUDDER ANGLE °

POSEIDON RPM

POSEIDON COMPASS

POSEIDON GYRO 050.9°

POSEIDON SATELLITE COMPASS 051.0°

POSEIDON - your maritime training partner

POSEIDON ENGINE

POSEIDON RPM

POSEIDON TIME 18:04:07
LOG 003.3

POSEIDON SIMULATION CONTROL
EXERCISE STATUS

POSEIDON SCREEN 1 SCREEN 2
CONNECT

POSEIDON HELP EXT
CONFIG





**Fleksible interface moduler
gir enkel tilgang til:**

**-Hardware styring av
autopilot og NFU joystick**



**-Hardware kontroll av
radar**



-Repeatere av ulike slag

-Feilsituasjoner

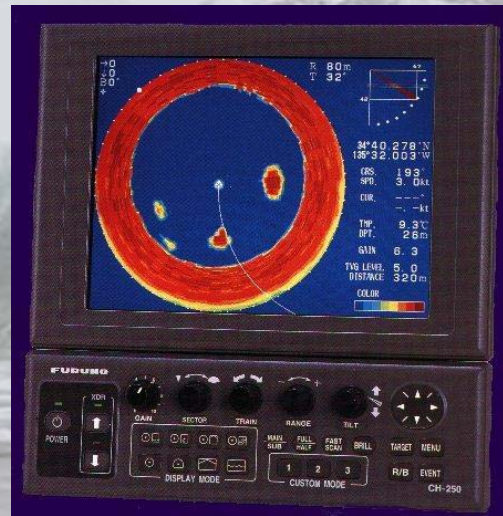
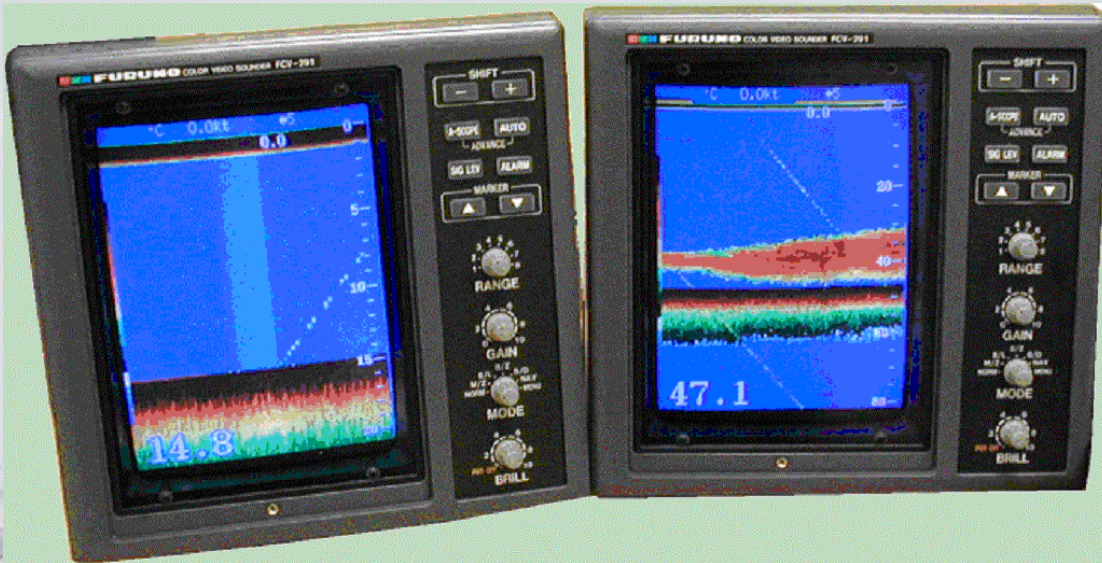

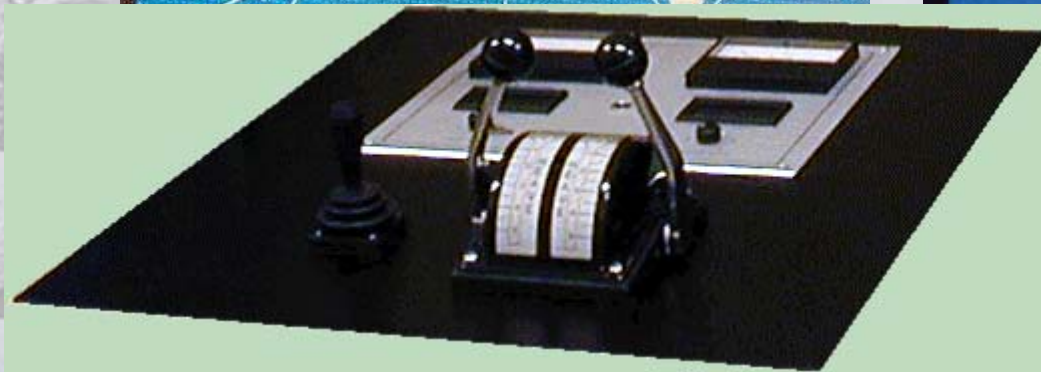
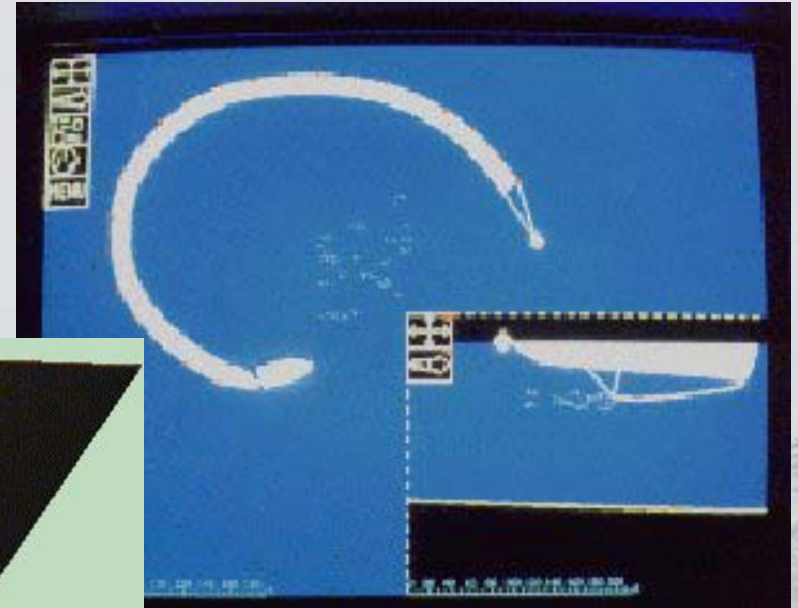
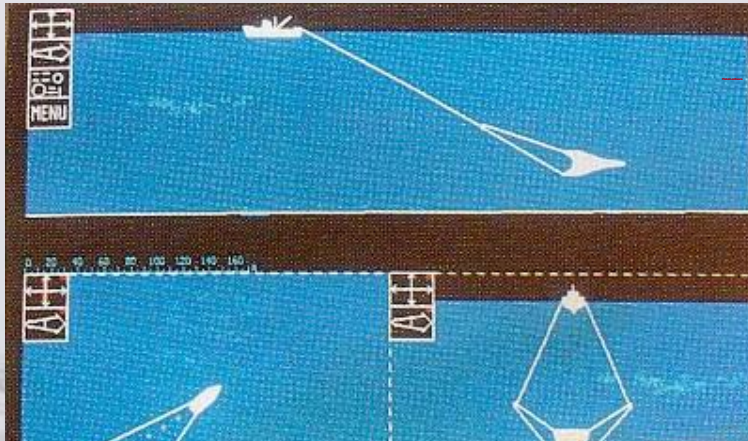



Ny SATC
Bærbar VHF
LÆREBØKER!

POSEIDON

LATITUDE	LONGITUDE	DATE	TIME	STATION	STATUS
		23 Oct 2002	11:35:27	Instructor	IDLE

Maskinromssimulatorer

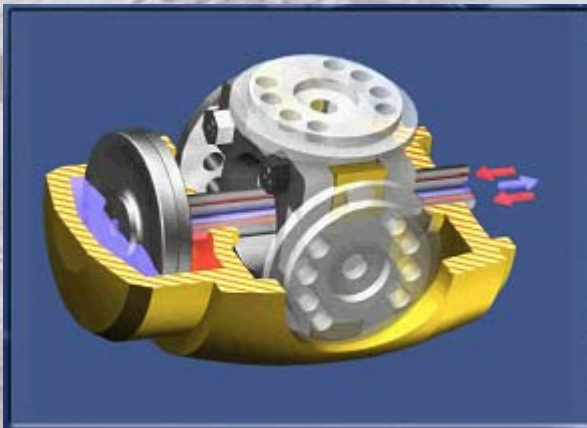
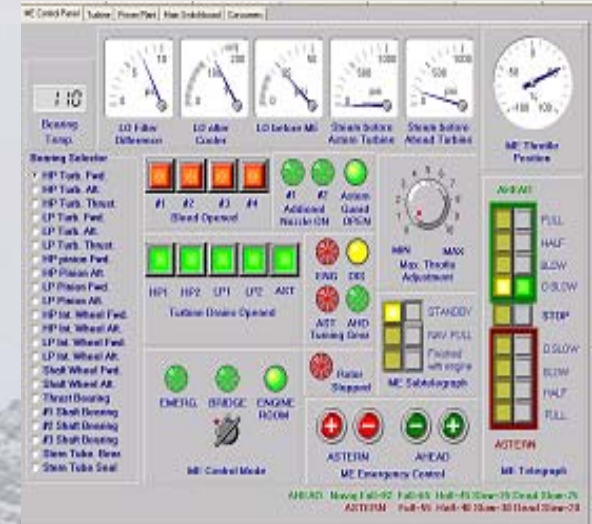

**Full mission,
Desktop,
PC simulatorer
CBT programmer**

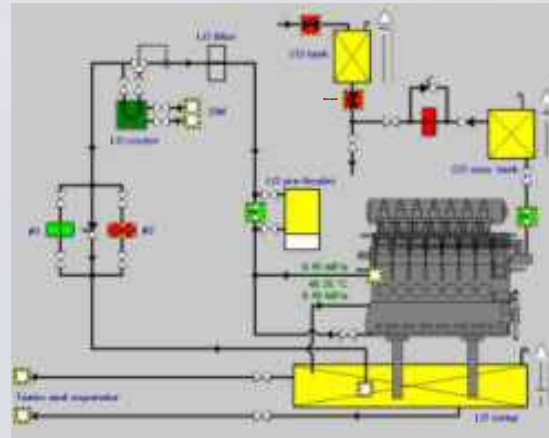
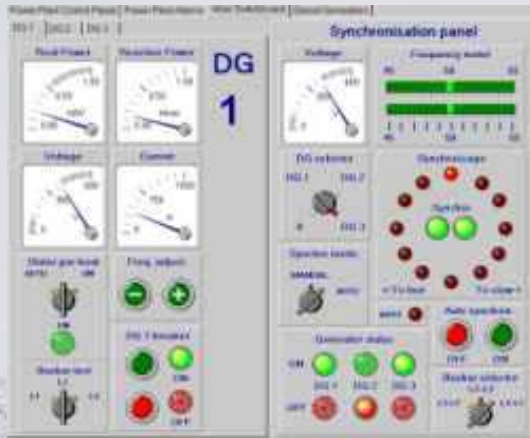

SLOW SPEED



MEDIUM SPEED

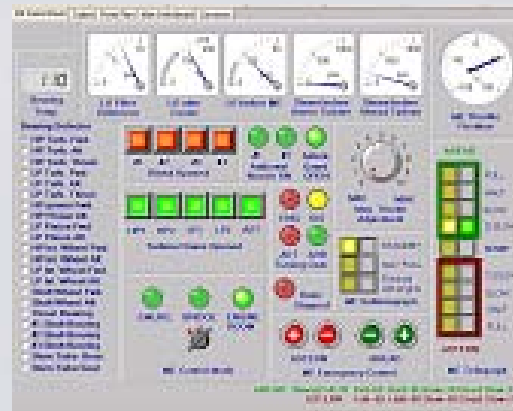
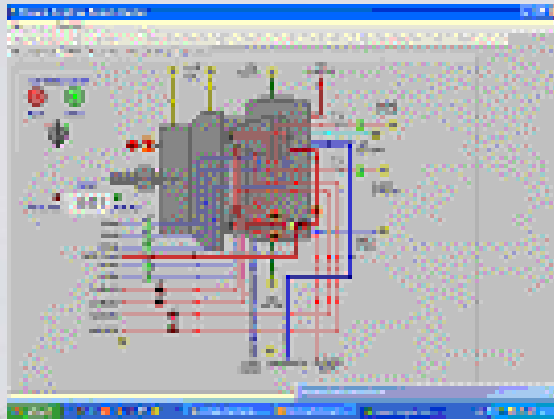

SER (SEC) main features:

- Realistic look and feel.
- Steam turbine as a main engine.
- Auxiliary systems.
- Controls and alarms.
- Multiple mimic diagrams for operation and monitoring.
- Multichannel digitized sound.
- It is possible to switch between metric and US units.

STEAM ENGINE

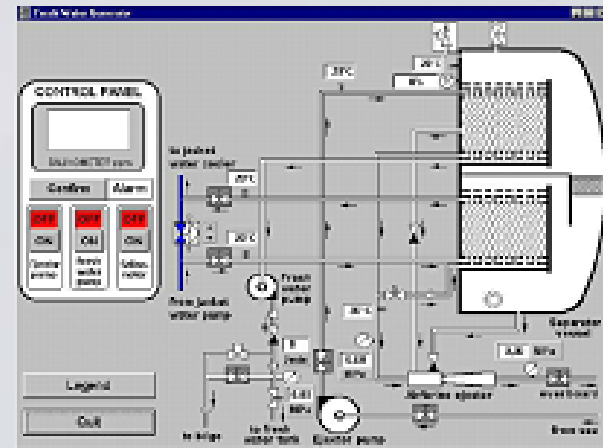
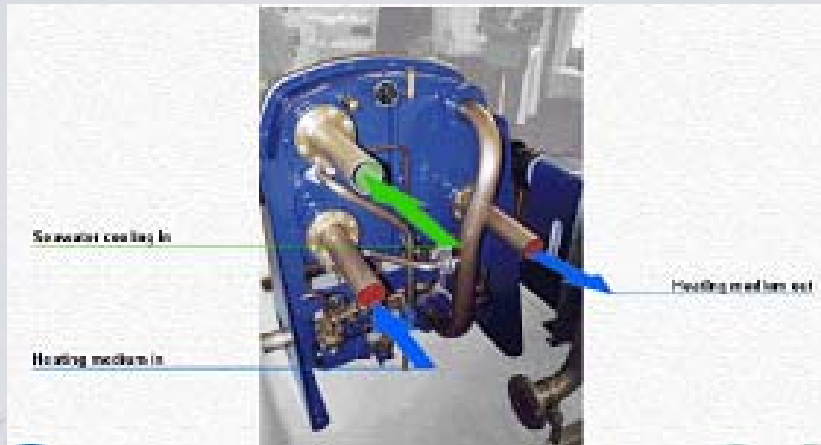

- Water pumps
- Hydrophore installation
- Freshwater generator
- Reverse osmosis desalination system
- Piston compressor
- Refrigerating plant
- Fixed delivery pump steering gear installation
- Variable delivery pump steering gear installation
- Controllable pitch propeller installation
- Oily water separator
- Biological sewage treatment plant
- Auxiliary steam boiler installation
- Combined oil fired and exhaust gas boiler
- Fuel oil treatment plant
- ALFA LAVAL, S – type separation system
- Diesel engines
- Diesel engine generators
- Marine Diesel engine monitoring systems
- Remote control system AUTOCHIEF 4 for SULZER RTA engines
- Remote control system AUTOCHIEF 4 for SULZER B&W engines

CBT

- System description
- Operating instructions
- Test
- Interactive simulator



DET NORSKE VERITAS
QUALITY SYSTEM CERTIFICATE

Certificate No. 2001-OSL-AQ-7055

This is to certify that
THE QUALITY SYSTEM
of

Poseidon Simulation AS

at
Næringsparken, Lufthavnvn. 11, P.O. Box 89, 8376 Leknes, NORWAY

has been found to conform to the Quality System Standard
NS-EN ISO 9001, 1994

This Certificate is valid for the following product or service ranges:
Development, marketing, sales, installation and service of simulator software and hardware for professional maritime training.

Original certificate valid from:
2001-04-09

This Certificate with Appendix is valid until:
2003-12-15

Dag Julian Eilertsen
Lead Auditor



Place and date:
Høvik, 2001-04-30

For the accredited unit:
Det Norske Veritas Region Norge AS

Torger Baardseth
Torger Baardseth
Management Representative

Lack of fulfilment of conditions as set out in the Appendix may render this Certificate invalid.

DET NORSKE VERITAS REGION NORGE AS, Veritasveien 1, N-1322 Høvik, Tel: +47 67 57 99 00, Fax: +47 67 57 99 11
AQN-23uk 22.12.2000

**ISO 9001
Certified
by
DNV**

TAKK FOR MEG!

POSEIDON

- your maritime training partner

Tlf: 760 54330

epost: atveit@poseidon.no